



35.000 dwt bulk carrier exhaust gas emission reduction concept study

December 2009

| | | |
|-----------|---|----------------------|
| Published | : | 20 November 2009 |
| Project | : | 40.5070.00 |
| Prepared | : | Søren Schnack |
| Checked | : | Hans Otto Kristensen |

| TABLE OF CONTENTS | | PAGE |
|--------------------------|--|-------------|
| 1 | INTRODUCTION | 4 |
| 1.1 | Purpose | 4 |
| 1.2 | Emission regulations | 5 |
| 1.3 | Emission reduction methods | 7 |
| 2 | THE REFERENCE SHIP SEAHORSE 35 | 8 |
| 2.1 | Outline description | 8 |
| 2.2 | Main data | 9 |
| 2.3 | Fuel consumption and emission | 10 |
| 2.4 | General arrangement | 10 |
| 2.5 | Machinery arrangement | 10 |
| 2.6 | Electrical power balance | 12 |
| 2.7 | Load profile | 12 |
| 3 | MODIFICATIONS TO THE BASIS SHIP | 13 |
| 3.1 | List of modifications | 13 |
| 3.2 | Speed nozzle / propeller and twisted spade rudder / Costa-bulb | 13 |
| 3.3 | De-rating of main engine | 15 |
| 3.4 | Water in fuel (WIF) | 15 |
| 3.5 | Exhaust gas recirculation (EGR) | 17 |
| 3.6 | Waste heat recovery system (WHR) | 19 |
| 3.7 | Exhaust gas scrubber | 21 |
| 3.8 | Ducted / direct air intake for main engine | 22 |
| 3.9 | Optimised coolers and cooling pumps | 23 |
| 3.10 | Auxiliary engine and boiler operation on marine gas oil (MGO) | 23 |
| 3.11 | High capacity fresh water generator | 23 |
| 3.12 | Installation of ballast water treatment System (BWT) | 24 |

| | | |
|----------|--------------------------------------|-----------|
| 4 | CONSEQUENCES OF MODIFICATIONS | 25 |
| 4.1 | Space considerations | 25 |
| 4.2 | Effect on electrical power balance | 27 |
| 4.3 | Steam balance | 28 |
| 4.4 | Emission reductions | 29 |
| 4.5 | Deadweight loss | 34 |
| 4.6 | Economical consequences | 34 |
| 5 | EMERGING TECHNOLOGIES | 36 |
| 5.1 | Air Lubrication and/or micro bubbles | 36 |
| 5.2 | Low friction bottom paint | 36 |
| 6 | OPERATIONS | 36 |
| 6.1 | Effect of speed reduction | 36 |
| 7 | CONCLUSIONS AND FINAL REMARKS | 38 |

1 INTRODUCTION

1.1 Purpose

The purpose of this bulk carrier concept study is to show the effect of selected existing technologies and operational means to reduce exhaust gas emissions from ships.

This bulk carrier study is one of two studies supported by the Danish Maritime Foundation and part of the many projects under Green Ship of the Future – aimed to demonstrate the potential of maritime exhaust gas emission reducing technologies, primarily used by Danish partners, and to show that high exhaust gas emission reductions may be obtained, with following main targets:

CO₂: 30 % reduction

NO_x: 90 % reduction

SO₂: 90 % reduction

The following describe the basis ship and the selected GSF emission reducing technologies necessary to achieve these reductions, which are more ambitious than the rules expected to come into force in the coming years.

The case study integrates and quantifies the main effects of selected 'green systems'. Most of the systems have been custom designed for the case study, by partners in the 'Green Ship of the Future' network. The main technical system data, including emission, consumption and cost data, also originate from the system designers:

- | | |
|---------------------------------|-------------|
| • MAN Diesel, Copenhagen | GSF partner |
| • MAN Turbo, Hamburg | GSF partner |
| • Aalborg Industries, Aalborg | GSF partner |
| • Force Technology, Lyngby | GSF partner |
| • DESMI Pumps, Nørresundby | GSF partner |
| • APV Heat Exchanger, Kolding | GSF partner |
| • Atlas-Danmark, Nr. Alslev | |
| • Alfa Laval, Copenhagen | |
| • Grontmij Carl Bro, Glostrup | GSF partner |

1.2 Emission regulations

As illustrated below the international rules concerning NO_x, SO_x and particular matter will be tightened in the future.

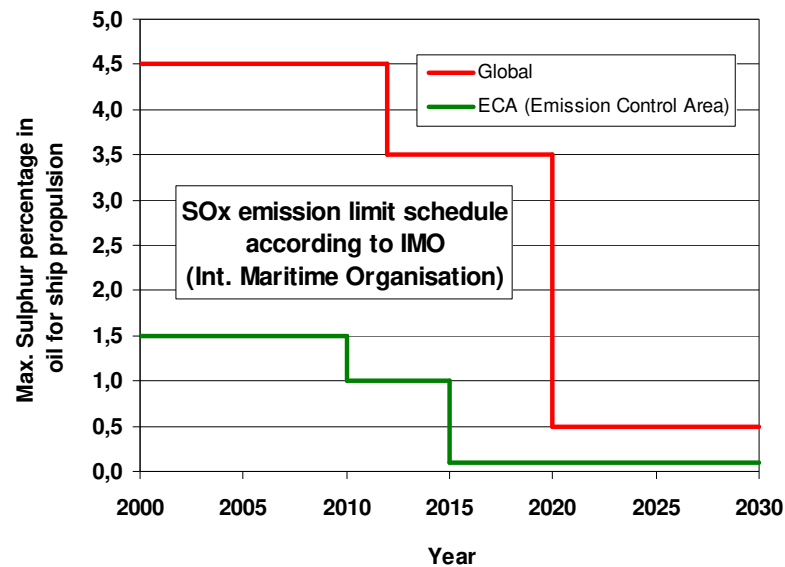

Throughout the world, national and regional governments tend to extend the Emission Control Areas (ECA's). Lately, the US and Canada have put forward a proposal, that will extend their emission control areas to 200 nautical miles from the coast.

It demands use of fuels containing less than 0,1% sulphur from 2015 as well as an 80% NO_x reduction from 2016. In lieu of low sulphur FO the proposal calls for exhaust gas cleaning devices, so called scrubbers, as the world production of low sulphur FO can not meet the demand.

The EU is going to limit the sulphur content of fuels to 0.10% in EU ports from January 2010.

Since May 2009, California has limited the sulphur content of fuels to 0.50% in ports and within 24 nautical miles from the coastline.

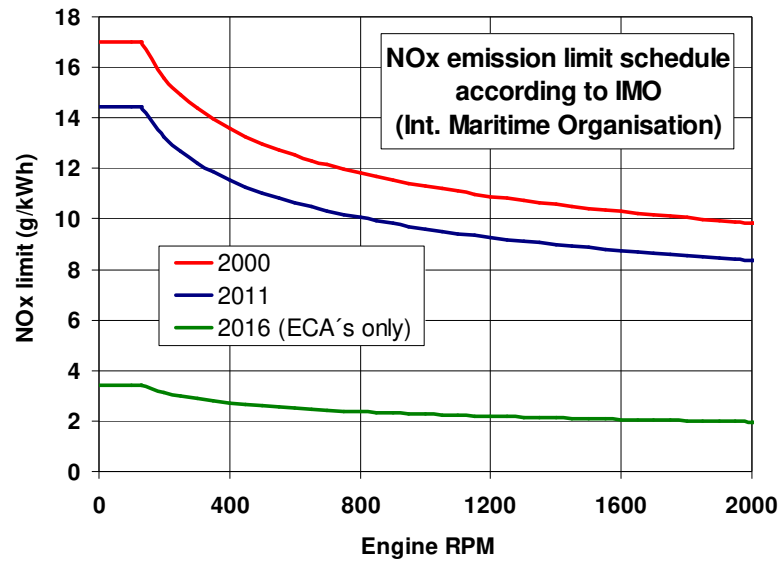

The rules coming into force concerning NO_x emissions are internationally controlled by the IMO and, to some extent, by national governments stating separate requirements for NO_x within ECA areas.

Concerning CO₂ it is expected, that rules for ships will come into force in the near future, both internationally and regionally. For the moment, however, the only concrete step, is the probably coming rules enforcing CO₂ indexing of new ships. 3 % of the worlds CO₂ emission has been calculated to come from ship transport (IMO GHG study, July 2009)

1.3 Emission reduction methods

Listed below are some of the emission reduction measures, which have been mentioned in recent years. The claimed potential for each measure is listed as well. The idea of this concept study is to determine, for a specific ship design, the combined effect of some of these measures.

| MEASURE / METHOD | CO2 Reduction | NOx Reduction | SOx Reduction |
|--|--------------------------|--------------------------|--------------------------|
| MACHINERY | | | |
| Dual / Multi MCR certification | 1 to 3 % | | 1 to 3 % |
| Turbo charging with variable nozzle ring | | | |
| WHR systems (Waste Heat Recovery) | 8 to 10 % | 8 to 10 | 8 to 10 % |
| EGR systems (Exhaust Gas Recirculating) | -2 to -3 % | 80% | 19% |
| Auxiliary systems optimisation | 1,5 % | 1,5 % | 1,5 % |
| Automated engine monitoring | 1 % | | 1 % |
| Scrubber systems | 3 % | | 98 % |
| Optimized control for ship cooling | | | |
| LNG fuel | 25 % | 35 % | 100 % |
| WIF systems (Water In Fuel) | increase 1 to 2 % | 30 to 35 % | increase 1 to 2 % |
| PROPULSION | | | |
| ACS (Air lubrication system) | 5 to 10 % | 5 to 10 % | 5 to 10 % |
| Innovative propeller | Not yet known | Not yet known | Not yet known |
| OPERATION | | | |
| SIMAC GSF student forum | Not yet known | Not yet known | Not yet known |
| Performance monitoring of silicone antifouling | 4 to 8 % | 4 to 8 % | 4 to 8 % |
| Lab on a ship | 0 to 5 % | 0 to 5 % | 0 to 5 % |

2 THE REFERENCE SHIP SEAHORSE 35

2.1 Outline description

The bulk carrier study is based on the Grontmij | Carl Bro designed SEAHORSE 35 which is a new generation, shallow draft, wide hatched and geared 35,000 DWT Handy size Bulk Carrier with double hull. The vessel is laid out with 5 cargo holds, equipped with end-folding hydraulically operated hatch covers and 4 x 30 t deck cranes. The SEAHORSE 35 is designed to accommodate the latest trends and developments within the Handy size Bulk Carrier trade. For the time being, eight SH35's are on order at Chinese yards. The keel has been laid for the first two. The design is based on Grontmij | Carl Bro's previous handy size bulker, the Diamond 34, of which two have been completed and are ready for sea trial, and four more are on order.

The SEAHORSE 35 is a future-orientated design incorporating a wide range of operational features and expected future safety regulations. The following items have been emphasized in the design:

- Economical operation/maintenance
- Environmental friendliness
- Loading flexibility and robustness
- Future regulations for Bulk Carriers
- Safety

The double hull concept ensures easy discharging and cargo hold cleaning, as well as a strong and robust hull structure, able to withstand the demanding service of bulk carriers. The absence of hopper tanks, as well as an efficient cargo hold cleaning system, contributes to an effective cargo operation.

Low maintenance costs are ensured by a high quality paint specification, ballast pipes and valves arranged in double bottom pipe duct and service systems, such as fire main line, compressed air, hydraulic piping and cables are arranged in the wing tank pipe ducts.

The safe operation of the SEAHORSE 35 is improved by the double hull, which forms a second barrier against accidental water ingress and allows safe access for close-up survey of the complete hull structure, even when the vessel is loaded. Green water protection of forecastle air pipes, ventilation heads and stores hatch are provided by the breakwater, and a protected under-deck passage to the fore deck improves the safe operation of the vessel.

The environmental friendliness is ensured by low emission machinery, easy ballast water exchange and the arrangement of a cargo hold washing-water holding tank. Furthermore, to minimise the risk for oil spill, all heavy fuel oil and diesel oil is stored in protected location tanks away from the ships shell plating.



2.2 Main data

The main data of the basis ship are:

| | | |
|--|------------------|----------------|
| Length over all | 180.0 | m |
| Length PP | 176.75 | m |
| Breadth | 30.00 | m |
| Depth | 14.7 | m |
| Draught | 10.1 | m |
| Deadweight | 35,000 | tons |
| Cargo hold cubic (grain) | 46,700 | m ³ |
| Gross tonnage | 23,800 | GT/NT |
| Net tonnage | 10,500 | |
| Main engine (TIER I): | MAN 5S50ME-B9 | |
| Main engine power output (SMCR) | 7410 | kW |
| Revolutions | 117 | RPM |
| Diesel generators: | 3 x 600 | kW |
| Propeller, fixed pitch, keyless | 5.6 m, 4 blades, | |
| Service speed at design draught and with a propulsive power of 6.300 kW corresponding to 0.85 x SMCR | 14.0 | knots |

2.3 Fuel consumption and emission

The specific oil consumption of main and auxiliary engines, respectively, is 159.3 g/kWh and 200.0 g/kWh, under ISO conditions. These are catalogue values, which will be used throughout the report.

The total oil consumption at 14.0 knots service speed and with an electrical load of 376 kW, according to the electric al balance, is thus:

$$(6300 \times 159.3 + 376 \times 200 / 0.95) \times 24 / 1.000.000 \text{ tons/day} = \underline{26 \text{ tons/day}} \text{ (ISO conditions)}$$

The emission during normal navigation at service speed, based on heavy fuel oil with a sulphur content of 3%, will be:

| | |
|---------------------------|------------------------|
| CO ₂ : | 85.4 tons per 24 hours |
| SO _x : | 1.6 tons per 24 hours |
| NO _x : | 2.7 tons per 24 hours |
| Particulate matters (PM): | 0.3 tons per 24 hours |

2.4 General arrangement

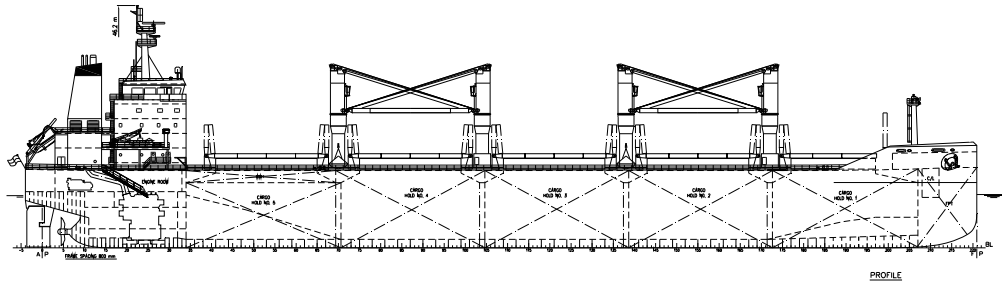

2.5 Machinery arrangement

The machinery arrangement for the bulk carrier is concentrated around the main engine with all the ancillary systems distributed on the different deck from tanktop to casing.

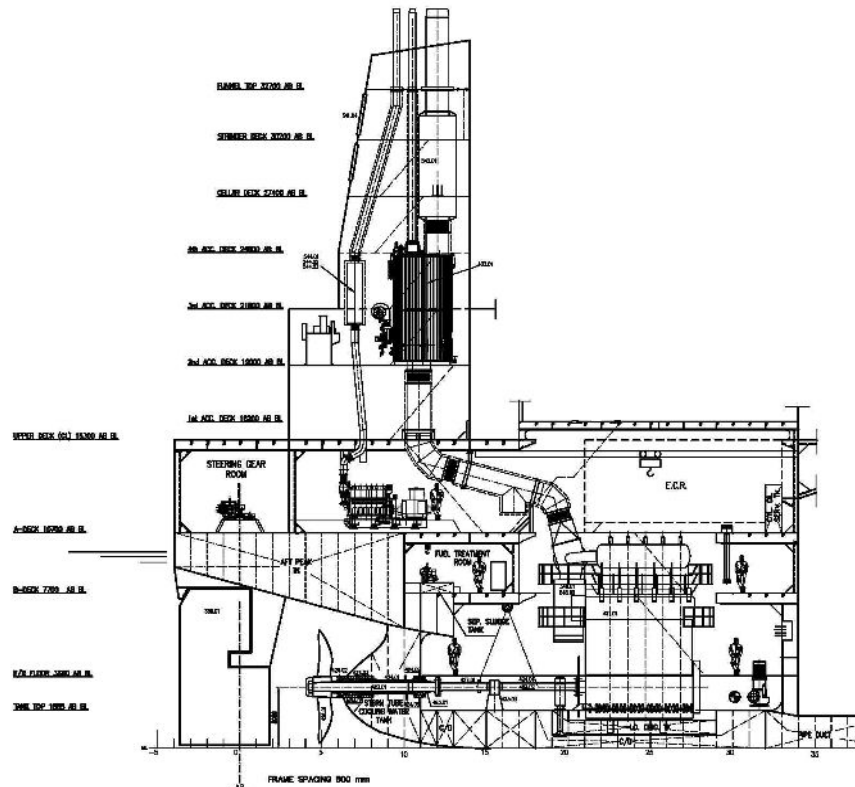

Following 'green technologies' are already incorporated for these vessels:

- Exhaust gas boiler utilizing main engine exhaust heat to generate service steam
- Waste water treatment according to IMO / SOLAS requirements
- Protected location of oil tanks (double hull) to minimize fuel spill in case of grounding or collision.

2.6 Electrical power balance

Extract of electrical power balance for the basis ship

| ELECTRIC POWER GENERATING EQUIPMENT: | QTY' | POWER |
|--|------|-------|
| DIESEL GENERATOR SET (GENERATOR CAPACITY) [kW]: | 3 | 500 |
| EMERGENCY DIESEL GENERATOR SET (GENERATOR CAPACITY) [kW] | 1 | 100 |

| ELECTRICAL BALANCE GROUP: / CONDITION: | LOAD [kW] | | | | |
|---|------------|---------------------------|------------|-------------------|------------|
| | AT SEA | AT SEA, BALL. EXCH. | MANOEUV | CARGO HANDLING | HARBOUR |
| GROUP 1 PROPULSION SERVICE [KW]: | 43 | 43 | 100 | 5 | 5 |
| GROUP 2 OTHER AUX SYSTEMS IN E/R [KW]: | 124 | 244 | 141 | 123 | 177 |
| GROUP 3 DECK MACHINERY [KW]: | 0 | 0 | 21 | 21 | 21 |
| GROUP 4 CARGO GEAR [KW]: | 0 | 0 | 0 | 557 | 0 |
| GROUP 5 VENTILATION [KW]: | 117 | 117 | 117 | 87 | 88 |
| GROUP 6 OTHER AUX. SYSTEMS OUTSIDE E/R [KW]: | 18 | 18 | 43 | 2 | 2 |
| GROUP 7 GALLEY AND LAUNDRY [KW]: | 23 | 23 | 23 | 23 | 23 |
| GROUP 8 220 V INSTALLATION [KW]: | 39 | 39 | 39 | 58 | 59 |
| TOTAL POWER DEMAND [KW]: | 365 | 485 | 484 | 875 | 375 |
| TOTAL POWER DEMAND INCL. 3% SAFETY MARGIN: | 376 | 499 | 498 | 902 | 386 |
| AUX. ENGINE SETS RUNNING: | 1 | 2 | 2 | 2 / 3 | 1 |
| EMERGENCY DIESELGENERATOR RUNNING: | | | | | |
| GENERATOR LOAD: | 75% | 50% | 50% | 90% / 60% | 77% |

2.7 Load profile

Time distribution of engine and boiler loads

| | at sea | at sea ballast exchange | manoeuv. | unloading | loading | total |
|------------------------------|------------|-------------------------------|-----------|-----------|-----------|------------|
| operating days / year | 225 | 5 | 10 | 60 | 60 | 360 |
| main engine | | | | | | |
| power/SMCR | % | 85 | 85 | 50 | | |
| power | kw | 6300 | 6300 | 3706 | | |
| diesel generators | | | | | | |
| electrical load | kw | 365 | 485 | 484 | 875 | 375 |
| oilfired boiler | | | | | | |
| steam production | kg/h | | | 782 | 782 | |

3 MODIFICATIONS TO THE BASIS SHIP

3.1 List of modifications

The following developed technologies have been selected for the concept study to evaluate the effect on emissions, electric balance (and fuel consumption), space requirement, budget costs and cargo intake for this ship design if all these technologies were included:

The technologies are:

- Speed nozzle / optimized propeller / ME derating
- Twisted spade rudder with Costa bulb
- Water in fuel (WIF)
- Exhaust gas recirculation (EGR)
- Waste heat recovery system (WHR)
- Exhaust gas scrubber
- Ducted/direct air intake for main engine
- Optimised coolers and cooling pumps
- Auxiliary engine operation on marine gas oil (MGO)
- High capacity fresh water generator
- Installation of ballast water treatment System (BWT)

3.2 Speed nozzle / propeller and twisted spade rudder / Costa-bulb

The propeller diameter on a bulk carrier is normally restricted, due to propeller immersion requirements at ballast draught, leading to a relatively high propeller loading. This, in connection with the low speed, typical of a bulk carrier, leads to a relatively low propeller efficiency. The reason is, in principle, that the propeller thrust is relatively large compared to the mass flow through the propeller disc, meaning that a relatively high velocity increase of the flow is necessary, leading to a relatively high level of kinetic energy in the propeller wash.

Propeller nozzles have been utilized for many years to overcome this type of problem, on tugs, trawlers and other vessels using relatively high power at low speed, and with a restricted propeller diameter, either due to space or RPM restrictions.

For applications where the speed is slightly higher, such as a bulker, the nozzle is called a speed nozzle, but the principle is the same. The circulation around the nozzle's wing section is utilized to increase the contraction of the flow forward of the propeller, and in a corresponding manner divert the flow aft of the propeller, thus creating a flow pattern equivalent to the flow generated by a larger propeller.

In practice this leads partly to the transfer of thrust from the propeller to the nozzle. The propeller design will of course have to be adapted for, and optimized together with the nozzle. The standard propeller diameter on the Seahorse is 5.6 m. When fitting a propeller nozzle, the critical parameter is going to be the nozzle's outside diameter. It was decided to allow a slight increase to 5.8 m, which means the clearance above the baseline will be reduced by 100 mm.

The idea of the twisted rudder is to align the rudder blade to the flow direction in the propeller wash. For a right hand turning propeller the wash above the shaft will be deflected somewhat to starboard, whereas the flow will be deflected somewhat to port, below the shaft. On the twisted rudder, the upper and lower part of the blade, are angled relatively to each other, such as to give a better alignment with the flow for both parts. In order to minimize the rudder torque, for the rudder around neutral position, a certain symmetry between the upper and lower part of the rudder is necessary, which means that twisted rudders are normally made as full spade rudders.

The Costa bulb is a streamlined body fitted on the rudder, behind the propeller hub. It minimizes the hub vortex and its related loss, by providing a more homogeneous flow distribution behind the hub area.

The total reduction in propulsive power at service speed (85 % MCR), from the application of the above mentioned devices, has been estimated by FORCE Technology (the Danish ship model basin in Lyngby) to 4 % or 250 kW (reduced from 6,500 to 6,250 kW). The ship speed is unchanged.

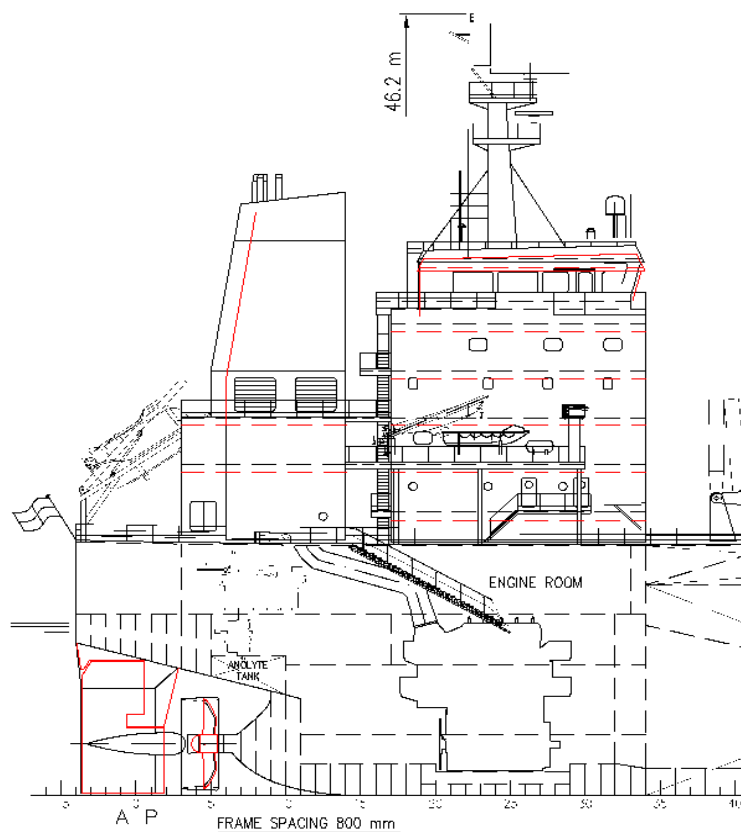

Aft body with modifications, including speed nozzle, spade rudder, Costa bulb, increased funnel and elevated accommodation block.

3.3 De-rating of main engine

The reduction in the propulsive power required, makes it possible to de-rate the main engine, which, at unchanged RPM, makes it possible to lower the ratio between mean effective pressure and maximum pressure in the combustion chambers. This increases the engines thermal efficiency, thereby reducing the specific fuel oil consumption.

The reference engine, an MAN 5S50 ME-B9, has a nominal maximum continuous rating (NMCR) of 8,900 kW at 117 RPM.

In order to deliver 6,300 kw at 85 % of specified maximum continuous rating (SMCR) in the basis ship, however, the engine's SMCR is reduced to 7,412 kW at 117 RPM, meaning that it is already de-rated. In order for the engine to deliver 6,050 kW at 85 % SMCR, the engine has been further de-rated to 7,118 kW at 117 RPM.

3.4 Water in fuel (WIF)

Operating on WIF gives the following possibilities:

- Based on already obtained experience the effect of adding 50 % water to the fuel is expected to give a 30-35% NO_x reduction of the exhaust gas, at the expense of an increase in CO₂ emissions of 1-2%.
- To be used as an alternative measure to reduce the NO_x level instead of mechanical adjustments / modification of the engine and thereby being able to fulfil the IMO Tier II limit.
- To be used to reduce CO₂ emission together with turbochargers with variable nozzle area, as the maximum fuel oil reduction potential cannot be obtained operating on fuel only (without WIF) as the NO_x emissions would exceed an unacceptable level.

The mechanism of water in fuel

WIF is believed to decrease the NO_x formation because the peak temperature is lowered due to the higher heat capacity of water vapour (compared to ambient air) and the heat absorption by water vaporization. It has also been observed, that the formation of PM is lowered when WIF is employed, which can be explained by the phenomenon micro-explosions or secondary atomization of emulsified fuel. This occurs, because the boiling point of water is lower than that of the surrounding fuel oil. The overall effect of the improved mixing of fuel with the combustion air is a decrease of the final CO, THC and PM concentrations. The improved mixing is also due to an increased momentum of the vaporized fuel jet (the mass is increased due to addition of water), which also improves the mixing. The presence of water in the fuel leads to a potential ignition delay, which means that more time for premixing of fuel and air is available. The last effect of WIF is an increased amount of hydroxyl radicals due to the higher water concentration. Hydroxyl radicals are essential in the oxidation of CO and THC.

Water in fuel on MAN two-stroke engines

MAN diesel delivers the main components of the system, assembled in a so-called WIF unit, plus the necessary modifications to the main engine.

Modifications to main engine:

In general the needed changes to ME/ME-C and ME-B engines are very limited, whereas the mechanical camshaft engine types MC and MC-C requires more changes.

Modifications to auxiliary systems:

When adding water to the fuel, the emulsion needs to be heated to a higher temperature than without water and the pressure in the system has to be increased in order to avoid evaporation of the water.

Furthermore, the auxiliary engines will be required to be supplied from a separate fuel oil system, as they will not be capable to operate on the same amount of water. The amount of water added is 50 % of the fuel, corresponding to app. 13.5 tonnes of fresh water per 24 hours. This means that a larger fresh water generator is needed; but enough heat is available from the main engine jacket cooling water system.

For newbuildings the extra investment is limited, as many of the components just differ a little from its specification and placement in the systems. For existing vessels the piping system and many of the components needs to be replaced, which will be relatively costly.

The WIF fuel system for the main engine is shown in the diagram on next page. The new components are a water in fuel measuring device, homogenizer, dumping tank, and an air driven back-up fuel oil supply pump for securing pressure in the fuel system, in case of black-out. The supply pump pressure must be increased from the normal 6 bar to 13 bar, meaning that all components in the re-circulation circuit, including the homogenizer, mixing tank, circulating pumps, preheaters, viscotherm, filter and main engine, must be designed for this pressure.

The preheating temperature must be increased to 180 deg. C, which cannot be obtained by heating with 6 bar service steam. A 14 bar steam system has been introduced, in order to boost the temperature of the fuel emulsion.

Water In Fuel system (WIF)

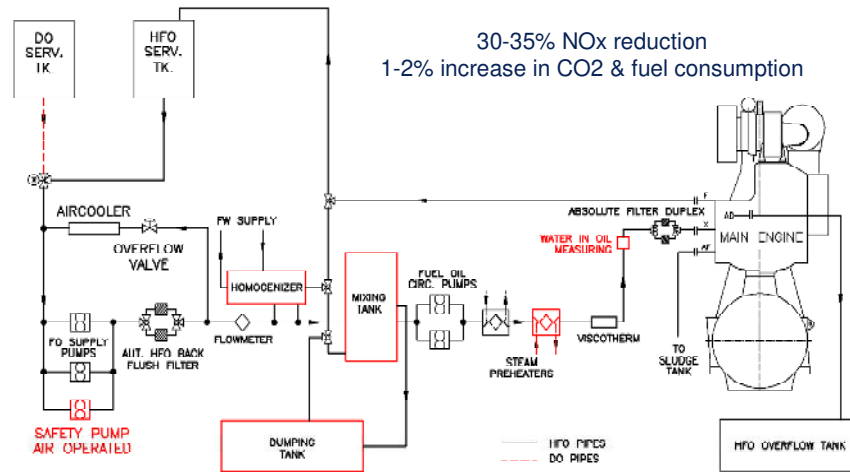

11

© 2009, Grontmij | Carl Bro A/S

Grontmij | Carl Bro

3.5 Exhaust gas recirculation (EGR)

This is a well known method of reducing NO_x emissions from internal combustion engines. The basic concept of the EGR technology is to reduce the peak combustion temperature, which suppresses the thermal formation of NO_x. EGR obtains this, partly because the heat capacity of the re-circulated exhaust gas is higher than that of normal combustion air (ambient air). Furthermore, the lower oxygen content (compared to the ambient air) in the re-circulated exhaust gas lowers the chemical reaction rate for the combustion of the fuel, thereby also reducing the peak combustion temperature.

MAN diesel's EGR system consists mainly of a pipe connection from the main engine's exhaust gas receiver, via an EGR unit, to the scavenge air receiver. The EGR unit consists of three parts:

- A scrubber unit which removes SO_x and particle matters from the re-circulated gas, to prevent this from damaging the engine. The scrubber uses re-circulated fresh water, which is being cleaned continuously and neutralised with NaHO, in a special water cleaning unit.
- A cooler ensuring that the re-circulated gas does not raise the scavenge air temperature significantly above the temperature of the air from the charge air coolers.

- A frequency controlled blower, which overcomes the pressure differential between exhaust gas receiver and scavenge air receiver, and controls the flow. The electrical power consumption of the blower is about 85 kW when the engine runs at 85 % SMCR, corresponding to service speed.

The recirculation ratio is 0.3 at full engine load, increasing to 0.4 for engine loads below 75 % SMCR. The fresh water consumption of the scrubber corresponds roughly to the water condensation from the exhaust gas, meaning that the requirement for fresh water is negligible.

The diagram below shows the principal system lay-out on the modified Seahorse design. The EGR unit is indicated in the recirculation loop. The intake filter, boilers and exhaust scrubber, are not part of the EGR system. The colour table shows the combined influence, on main engine emissions, of ME de-rating, WIF and EGR.

Scavenge air / exhaust system with EGR

5S50ME-B9 EGR + WIF emission change vs. reference

| SFOC | CO2 | SOx | NOx | PM |
|------|-----|-------|-------|-------|
| % | % | % | % | % |
| 3,5 | 3,5 | -28,5 | -80,0 | -49,7 |

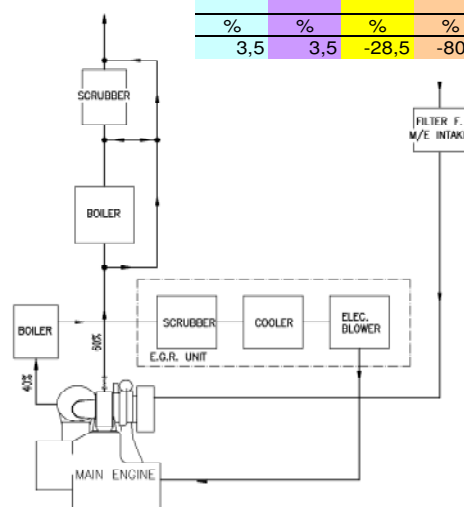

Grontmij | Carl Bro

13

© 2009, Grontmij | Carl Bro A/S

3.6 Waste heat recovery system (WHR)



Steam turbine generator

500 kw (electric) equal to 8.3 % of ME power

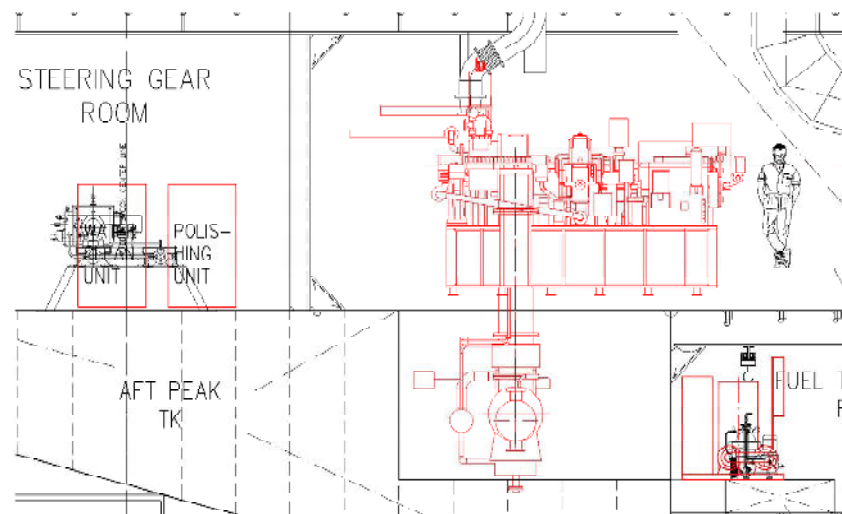

Grontmij | Carl Bro

21

© 2009, Grontmij | Carl Bro A/S

Waste heat recovery systems, with different degrees of sophistication, have been used on ships for decades, and with respect to CO₂, it gives by far the largest emission reduction, of the systems in this case study. Experience from existing installations, e.g. large container vessels owned by A.P.Møller-Mærsk, shows a potential for recovery of 10-15 % of the main engine power.

The system in this case study has been designed in a co-operation between MAN Diesel, Aalborg Industries and MAN Turbo. The steam turbine generator, which replaces one of the existing diesel generators, has been designed by MAN Turbo, and has an electric output of 500 kW, when sailing at service speed, corresponding to 8.3 % of the main engine output. The reason for this relatively modest output is, partly that the so called power turbine *) has been omitted for simplicity on this relatively small system, partly that a substantial portion of the generated steam must be used for fuel heating, not least due to the WIF system, and finally that the main engine exhaust gas temperature is relatively low, due to the de-rating. There is simply less wasted heat to utilize.

*) The power turbine (omitted) is similar to the turbine part of a turbocharger, and some of the exhaust gas is led through this, thereby bypassing the turbochargers. The power turbine is part of the steam turbine generator unit. It typically provides 15 - 25 % of the WHR output.

Steam System (WHR)

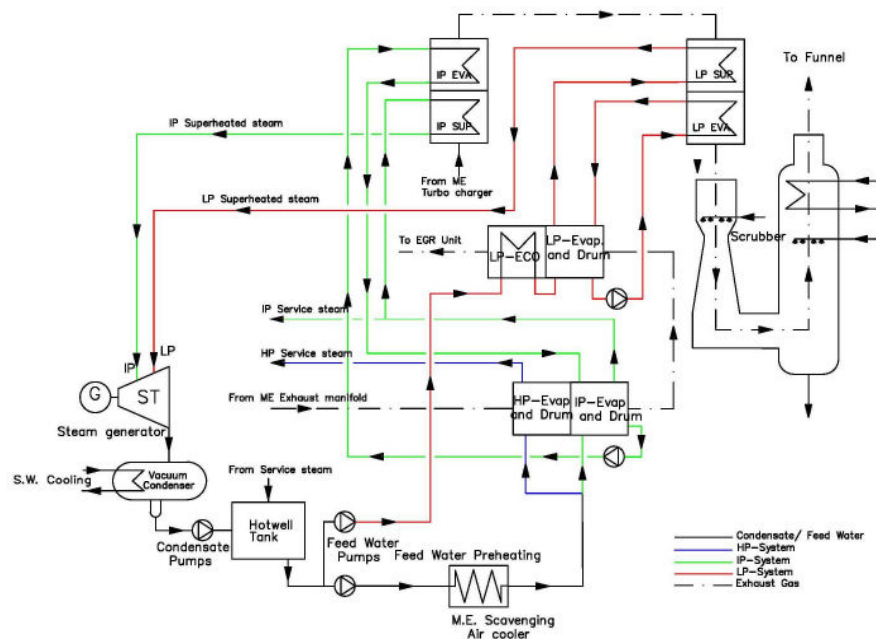

Grontmij | Carl Bro

20

© 2009, Grontmij | Carl Bro A/S

The vessels boiler plant has been designed by Aalborg Industries, and consists in total of six individual boilers, out of which four (intermediate and low pressure boilers) produces steam for the steam turbine:

High pressure (HP), intermediate pressure (IP) and low pressure (LP) exhaust boilers in the EGR circuit in the engine room. As the exhaust gas in the EGR system is under pressure, these boilers are of the firetube type. This also makes it possible to utilize the boilers as steam drums in the the HP, IP and LP pressure systems respectively.

IP and LP exhaust boilers as part of the uptake in the casing. These boilers are of the watertube type with forced circulation from the IP and LP steam drums respectively.

As the exhaust boilers are not able to be heated by oil-firing, unlike the original composite boiler, a small oil-fired boiler is also needed for start-up and harbour service.

In order to minimise the size of the heating surfaces (and boilers), the evaporation temperature and thus the steam pressure is generally kept low. The pressure levels in LP, IP and HP circuits are 0.5, 5.5 and 14 bar, respectively. The high pressure steam is only utilised to boost the preheating temperature of the fuel emulsion. In order to extract as much heat as possible, the exhaust gas is cooled down to app. 120 deg. C. This is considerably below the dew point of sulphuric acid, meaning that the last part of the LP exhaust boiler (LP evaporator) must be made from sophisticated materials.

The total amount of steam generated when sailing at service speed (85% SMCR) is about 4.6 t/h. The maximum capacity of the oil fired boiler is 1.2 t/h. More detailed information on exhaust and steam data for the different parts of the steam system can be found in the appendices.

3.7 Exhaust gas scrubber

The exhaust gas scrubber incorporated in this concept study is based on Aalborg Industries scrubber technology, which basically can be seen on this diagram:

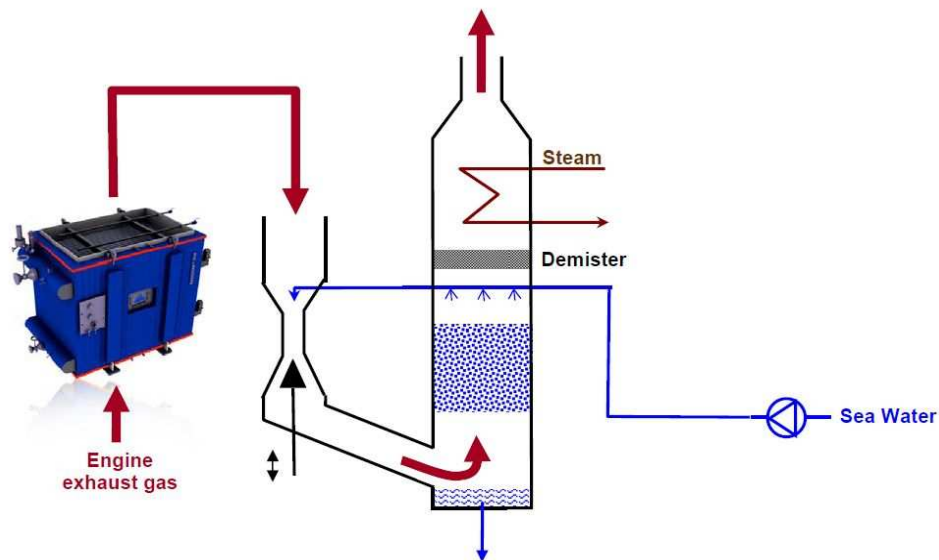

Scrubber system with sea water

The exhaust gas scrubber is a large component, and in order not to remove valuable heat from the exhaust gas, the scrubber must be arranged in the casing area after the exhaust boilers. The scrubber removes a high proportion of SO_x and particles (PM) from the exhaust gas, about 98 % and 80 % respectively. It is normally operated with seawater, and the sulphuric acid and particles, extracted from the exhaust gas, is washed into the sea, where the acid is converted to harmless sulphate. In coastal areas this potential air pollution might otherwise have been transported over land with the prevailing wind, and subsequently ended on the ground as acid rain.

The SW pump for the exhaust scrubber is one of the major consumers of electrical power, with a typical consumption of app. 50 kW, when sailing at service speed. It is advantageous, in order to minimize the lifting height of the water, and thereby the power consumption, to locate the scrubber unit as low as possible. The lay-out of the scrubber ensures the exhaust gas to enter from above, and leaving upwards. This is a simple way of forming a loop where the scrubber water can be controlled in a simple way, without running down into the boilers or even the engine. At the same time, it collects the water from water washing of the boiler above. The flow direction of the exhaust gas must now be changed 180 deg. twice, but this appears to be an advantage, both with respect to a low position of the scrubber, and with respect to the arrangement of bypass connections on the exhaust pipe.

In order to prevent droplets to escape from the scrubber, it is provided with a re-heater at the top, which raises the temperature of the exhaust gas by app. 10 – 20 deg. C.

In harbours, fjords, rivers or other sensitive areas, the scrubber may be operated with re-circulated fresh water, which is continuously being neutralized with sodium hydroxide (NaOH). The resulting sodium sulphate is considered to be harmless, and led overboard. The scrubber system can only operate on fresh water, up to a relatively low main engine load (e.g. 20 % SMCR). The loss of water from the scrubber during operation, means an additional fresh water consumption of 1.1 tonnes / 24h.

3.8 Ducted / direct air intake for main engine

This has been introduced in order to provide the main engine with air intake at the lowest possible temperature, thereby increasing the engine's thermal efficiency. This effect has not been quantified in the case study, but the system is well known, and has been used on all the large container ships from Odense Steel Shipyard. A reduction of the engine room ventilation has, however, been quantified. The number of fans has been reduced from three to two, and the average power consumption for engine room ventilation has been reduced from about 38 kW to about 14 kW, when the ship sails at service speed.

In order to keep a low air velocity in the duct (< 8 m/s), it must have a min cross-sectional area of about 1.6 m². Above upper deck level the duct consists of a trunk attached to the aft bulkhead of the accommodation, extending aft one frame spacing, and upwards along the two lower tiers of the accommodation block. The filters which need to have a larger area corresponding to about 4 m/s, can be accommodated in the trunk in way of the second tier. Below the upper deck level the trunk is lead directly to the main engine turbocharger intake.

3.9 Optimised coolers and cooling pumps

Most ships operate with pumps in the auxiliary systems, which have larger capacity than needed. The reason is that firm orders for pumps and coolers are placed at vendors, before the systems, for which the pumps are intended, have been designed. This means that the capacities specified are preliminary ones, often taken from the engine manufacturer's technical brochures. As a rule, these values are conservative. To obtain the proper flow, once the ship has been built, it is normal practice to install orifices in the systems. Needless to say, this practice is not very energy conscious. In order to optimize coolers and pumps, from a capacity point of view, it is necessary to perform an early assessment of the pressure drop of the pipe system in question. This can be done using various pipe flow calculation programs like 'Fluid Flow', which is being used by Grontmij | Carl Bro.

The optimisation for this case study has been carried out in cooperation with the pump manufacturer Desmi, and APV who manufactures plate coolers. Often the plate cooler represents a large proportion of the system's total pressure drop, and fitting a somewhat larger cooler may often contribute considerably to minimize the pumping power needed. Finally, the introduction of pumps, with coated interior and pumping wheels, has shown to reduce the power requirement by almost 10%.

The combined effect of these measures has been to reduce the power requirement of engine auxiliaries from about 167 kW to about 136 kW, when the ship operates at service speed.

3.10 Auxiliary engine and boiler operation on marine gas oil (MGO)

This measure almost lends itself, for several reasons:

As shown in the beginning of this report, the use of heavy fuel in ports is going to be restricted in the future.

The waste heat recovery system delivers most of the power at sea.

The WIF system makes a separate fuel oil supply system necessary for the auxiliary engines.

As can be seen in the section on emission reductions, this measure alone reduces the emission of SO_x, in or near harbours, by about 25 tonnes per year.

3.11 High capacity fresh water generator

The need for large quantities of fresh water for the WIF system, and, to a minor degree, the ballast water treatment and exhaust scrubber systems, requires additionally 17 tons/24hours, on top of the original production of 20 tons/24 hours, needed. In order to meet this requirement, the original fresh water generator must be replaced by a new high capacity fresh water generator from Alfa Laval (see appendices). This highly efficient set is utilising three stage evaporation, and is able to produce up to 48 tons/24 hours, with the heat available in the jacket cooling water, when the ship operates at service speed.

3.12 Installation of ballast water treatment System (BWT)

A special kind of pollution of the seas is the problem of invasive species, now being addressed by the IMO ballast water convention, which, though still in the process of being ratified, will require ballast water to be treated in order to prevent the spread of invasive species. Ballast water treatment is, strictly speaking, outside the scope of Green Ship of the Future; but depending of the type of system selected, it has potentially a large impact on the ship design, operation and energy consumption, which is the reason for it to be included. The system selected for this case study has been designed by ATLAS-DANMARK, and a description can be found in the appendices.

The basic principle is the use of 30 μ filters plus a so called active substance, called 'Anolyte'. An interesting feature is that the active substance is being produced onboard, while the ship is in service, and collected in a special tank. The tank capacity needed is about 60 m³, and may in principle be arranged in a part of a ballast tank, but in this case a part of the aft peak tank is used for this purpose. The active substance, is made from fresh water and ordinary salt (NaCl), by an electrolytic process. The average power requirement for the process is about 2 kW if the process takes place during the ballast voyage. The corresponding fresh water requirement is app. 2.2 tons per 24 hours.

4 CONSEQUENCES OF MODIFICATIONS

4.1 Space considerations

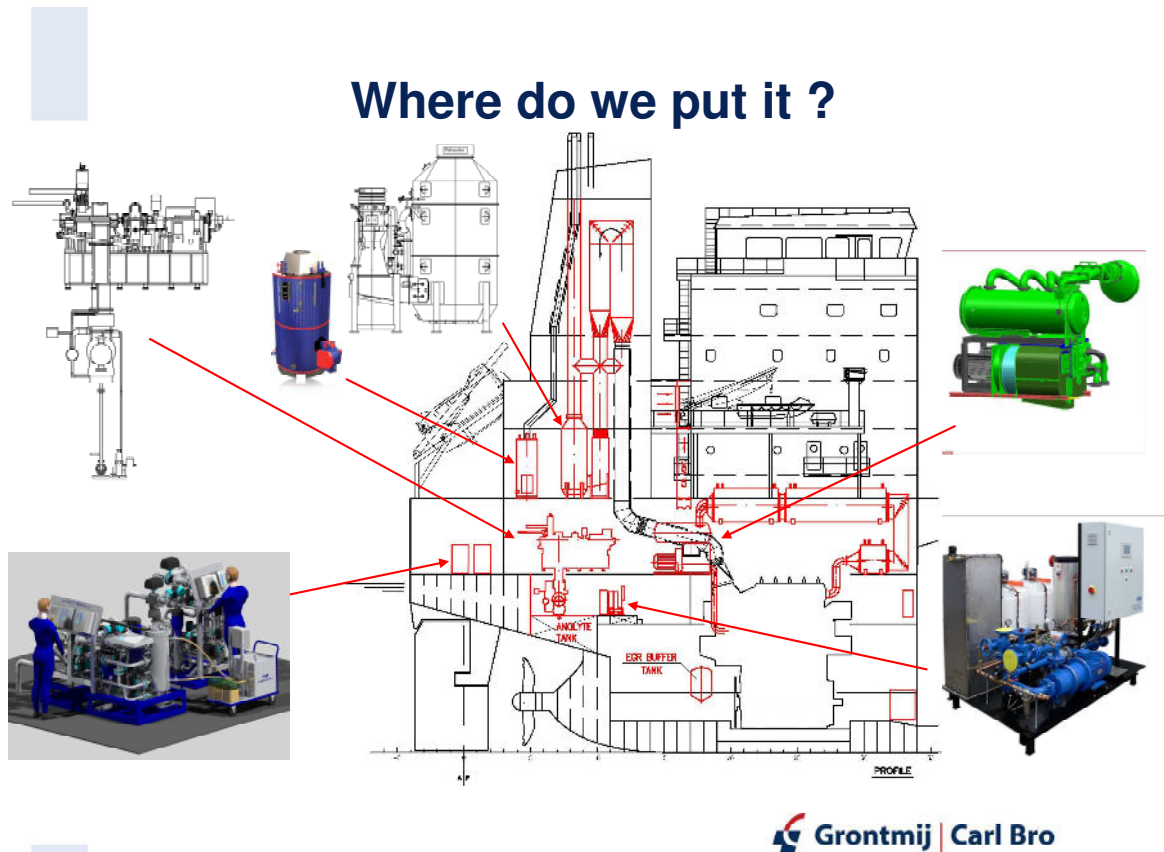

24

© 2009, Grontmij | Carl Bro A/S

Considering the amount and size of equipment, it proved to be relatively easy to fit all of the above mentioned systems into the ship's engine room and casing. The modified engine room is seen in the profile above, as well as a cross section and plan views, which can be found in the appendices.

The most difficult part to fit in has been the EGR circuit, with three boilers and a large EGR unit. An additional platform deck, for the large IP and LP boilers, has been situated between the A-deck and the upper deck level, in starboard side of the engine room, similar to the starboard part of the existing A-level platform deck. In order to create sufficient head-room for the fittings on top of the boilers, the whole accommodation block has been elevated by 500 mm. This is actually more straightforward, than it may sound, because of the existing cofferdam between upper deck and deckhouse, which simply has to be increased.

The introduction of the new platform deck, has limited the working area for the engine room crane, which originally spanned almost the full width between the longitudinal bulkheads. It is, however, still satisfactory, and with an outboard shift of the escape trunk, which is now being introduced on the Seahorse 35 design, it will be possible to regain most of the working area.

The steam turbine generator unit, even though larger and much heavier, fits neatly into the space of the diesel generator being replaced. Space for its condenser, however, has been provided by making a recess in the aft peak tank, with access from the oil treatment room. This room has also provided the space for the WIF unit, which is a most suitable location for this kind of equipment.

The exhaust boilers have been located in the funnel. The exhaust flows upwards in the IP boiler, through a box with two sets of vanes to change the flow direction, and downwards through the LP boiler, into the exhaust scrubber, where the flow is changed to upwards again. The scrubber and oil fired boiler, have both been located on the upper deck level. The funnel has been extended one frame spacing aft-wards, in order to accommodate this arrangement.

Tanks for sodium hydroxide (for scrubbers) and anolyte (for ballast treatment) have been arranged as built-in tanks, in the aft peak and a former cofferdam, respectively. The water treatment plants for the EGR scrubber have been located in the steering gear flat. The ballast water filters, part of the ballast water treatment plant, have to be located near the main ballast pipes near the engine room front bulkhead, at tank top level, where space is going to be restricted. Most of the additional pumps are going to be located at tank top level aft of the main engine, where space is also limited. The coolers, preheaters, steam turbine, condenser, feed pumps, circulation pumps and boilers, with their considerable number of economizers, evaporators and superheaters, have to be connected by a lot of piping, particularly as the IP and LP boilers in the engine room act as steam drums for the corresponding boilers in the casing. All told, it means the engine room is going to be significantly more complex than on the basis ship.

4.2 Effect on electrical power balance

Extract of electrical power balance for the modified ship

| ELECTRIC POWER GENERATING EQUIPMENT: | | QTY' | POWER | | |
|--|--------------------------------------|-----------|----------|----------------|---------|
| DIESEL GENERATOR SET (GENERATOR CAPACITY) [kW]: | | 2 | 1000 | | |
| WHR TURBO GENERATOR SET (GENERATOR CAPACITY at 85 % SMCR) [kW] | | 1 | 500 | | |
| EMERGENCY DIESEL GENERATOR SET (GENERATOR CAPACITY) [kW] | | 1 | 100 | | |
| ELECTRICAL BALANCE | | LOAD [kW] | | | |
| GROUP: / CONDITION: | | AT SEA | MANOEUV. | CARGO HANDLING | HARBOUR |
| GROUP 1 | PROPULSION SERVICE [kW]: | 40 | 97 | 6 | 6 |
| GROUP 2 | OTHER AUX SYSTEMS IN E/R [kW]: | 96 | 128 | 115 | 165 |
| GROUP 3 | DECK MACHINERY [kW]: | 0 | 21 | 21 | 21 |
| GROUP 4 | CARGO GEAR [kW]: | 0 | 0 | 557 | 0 |
| GROUP 5 | VENTILATION [kW]: | 94 | 94 | 85 | 85 |
| GROUP 6 | OTHER AUX. SYSTEMS OUTSIDE E/R [kW]: | 18 | 43 | 2 | 2 |
| GROUP 7 | GALLEY AND LAUNDRY [kW]: | 23 | 23 | 23 | 23 |
| GROUP 8 | 220 V INSTALLATION [kW]: | 39 | 39 | 58 | 59 |
| GROUP 9 | EMISSION CONTROL SYSTEMS [kW] | 175 | 132 | 0 | 0 |
| GROUP 10 | WASTE HEAT RECOVERY SYSTEM | 11 | 0 | 0 | 0 |
| TOTAL POWER DEMAND [kW]: | | 494 | 575 | 866 | 361 |
| TOTAL POWER DEMAND INCL. 3% SAFETY MARGIN: | | 509 | 592 | 892 | 372 |
| AUX. ENGINE SETS RUNNING: | | | 1 | 1 | 1 |
| TURBO GENERATOR (WHR) RUNNING: | | 1 | | | |
| EMERGENCY DIESELGENERATOR RUNNING: | | | | | |
| GENERATOR LOAD: | | 102% | 59% | 89% | 37% |

Electric consumption comparison between basis and modified ships

| | | | | | |
|--|----|-----|-----|-----|-----|
| Modified ship, consumption groups 1 - 8 | kW | 309 | 443 | 866 | 361 |
| Basis ship, consumption for groups 1 - 8 | kW | 365 | 484 | 875 | 375 |
| Change due to modifications, groups 1 - 8 | kW | -56 | -41 | -9 | -14 |
| Change due to modifications, groups 9 - 10 | kW | 186 | 132 | 0 | 0 |
| Change due to modifications, groups 1 - 10 | kW | 129 | 91 | -9 | -14 |

When the original consumers (groups 1 - 8) are compared, for the basis and the modified ship, it is seen that power consumption is lower on the modified ship. This is mainly due to pump and cooler optimization and saving in engine room ventilation power. It is also seen, that the power consumption of WHR system and, particularly, the various emission control systems is much larger than these savings. During normal navigation, two power consumers are responsible for the majority of this consumption, the EGR blower (85 kW) and the sea water pump for the exhaust scrubber (48 kW). A lot of smaller consumers also contribute to extra power requirement, such as:

- higher capacity fuel pumps in the WIF system
- fuel homogenizer

- sea water pumps for condenser cooling
- lubrication oil pumps for the steam turbine generator unit
- condensate, feed and circulation pumps
- higher capacity pumps for the fresh water generator (group 2)
- pumps for water treatment units in connection with scrubbers
- electrolytic generation of Anolyte for ballast water treatment
- control systems

As long as the total electrical power consumption during normal navigation, however, can be covered by the WHR, it does not contribute to the ships exhaust gas emissions. As can be seen, the actual consumption of 494 kW is lower than the rated capacity of the steam turbine generator of 500 kW, when operating at service speed, but there is virtually no margin. In practice a margin of about 10 % of the rated capacity of the generator is needed.

4.3 Steam balance

| Servic steam consumption | Cold condition: | | | | Normal condition: | | | | |
|--------------------------|------------------|--------|-------------|---------|-------------------|------------------|------------|------|------------|
| | Max cons kg/h | At sea | | In port | | Max cons kg/h | At sea | | In port |
| | | LF | kg/h | LF | kg/h | | LF | kg/h | |
| TOTAL: | | | 1221 | | 1020 | | 821 | | 809 |

Steam flow from exhaust boilers

| | | TC-Outlet | EGR-boiler | | |
|---------------|-------------|-----------|------------|-------|---|
| LP | | | | | |
| ECO | | | | | |
| EVAP | 1042 | 690 | 352 | kg/h | low pressure boilers conventional exhaust & EGR |
| Service steam | 0 | | | kg/h | |
| Pressure | 0,5 | | | barg | |
| Temperature | 160 | | | deg.C | |
| IP | | | | | |
| Flow | 2781 | 1176 | 1605 | kg/h | intermediate press. boilers conventional exhaust & EGR |
| Service steam | 700 | | | kg/h | |
| Pressure | 5,5 | | | barg | |
| Temperature | 400 | | | deg.C | |
| HP | | | | | |
| Flow | 210 | | 210 | kg/h | high pressure boiler EGR only |
| Service steam | 210 | | | kg/h | |
| Pressure | 14 | | | barg | |
| Temperature | 200 | | | deg.C | |

The upper table shows the service steam consumption in various conditions (a specified table can be found in the appendices). The lower table shows how much steam each boiler generates during normal navigation (85 % SMCR).

During normal navigation, the service steam consumption is about 821 kg/h of saturated steam at 5.5 bar. This figure has not changed significantly as a result of the modifications. The extra steam consumption caused by the increased fuel preheating, which is necessary due to the WIF system, is the most significant change; but it is not reflected in the above consumption figure. This extra consumption corresponds to the output from the high pressure boiler, e.g. 210 kg/h of saturated steam at 14 bar.

This leaves about 1,960 kg/h at 5.5 bar, plus the full output from the low pressure boilers, e.g. about 1,042 kg/h at 0.5 bar, for the steam turbine generator. Both of these steam flows are superheated. Out of a total amount of steam of about 4,033 kg/h, generated onboard, app. 3,002 kg/h, corresponding to 74 % is available for the WHR.

4.4 Emission reductions

The main engine

The emission figures for the modified engine, incl. de-rating, WIF and EGR, are shown in the tables below, together with the corresponding figures for the reference engine. The third table shows the relative change. The particle emissions is halved, and SO_x is reduced by app. 30 %, due to the exhaust scrubber. NO_x is reduced by 80 % due to WIF and EGR; but specific fuel consumption and CO₂ emissions are increased by 3.5 % (at 85 % SMCR) due to WIF and EGR. The WIF and EGR in combination make the engine to comply with Tier 3 requirements concerning NO_x. It should be emphasized, that these numbers are valid for the main engine, not for the ship's total emissions.

Low fuel consumption and low NO_x emissions are somewhat conflicting. One of the main factors in obtaining a high thermal efficiency is a relatively high combustion temperature; but this is unfortunately also one of the main drivers for a high formation of NO_x.

With respect to the values for specific fuel consumption and emissions, it shall be noted that the SFOC values, given by MAN Diesel, are always based on the calorific value of marine diesel oil, even though the emission values refer to heavy fuel oil with a sulphur content of 3 %. The CO₂ emission figures has been calculated from the internationally (IMO) agreed values of 3.11 kg CO₂ / kg HFO and 3.21 kg CO₂ / kg MDO. Even though heavy fuel oil gives lower CO₂ emissions than marine diesel oil, per kg fuel, it still gives a higher CO₂ emission for the same engine power, because the engine's consumption is higher when running on heavy fuel oil. The calorific value of heavy fuel oil is 40.5 MJ / kg versus 42.8 MJ /kg for marine diesel oil.

Main engine consumption and emissions

5S50ME-B9 de-rated + EGR + WIF (modified)

acc. to MAN diesel calc. acc. to MAN diesel acc. to MAN diesel acc. to MAN diesel

| Load | Power | SFOC (MDO) | CO2 | SOx | NOx | PM |
|------|-------|------------|-------|-------|-------|-------|
| % | kW | g/kWh | g/kWh | g/kWh | g/kWh | g/kWh |
| 85 | 6050 | 164,8 | 541,6 | 7,1 | 3,4 | 0,93 |
| 50 | 3560 | 168,2 | 552,8 | 7,2 | 3,4 | 0,75 |

5S50ME-B9-T1 (reference)

acc. to MAN diesel calc. acc. to MAN diesel acc. to MAN diesel acc. to MAN diesel

| Load | Power | SFOC (MDO) | CO2 | SOx | NOx | PM |
|------|-------|------------|-------|-------|-------|-------|
| % | kW | g/kWh | g/kWh | g/kWh | g/kWh | g/kWh |
| 85 | 6300 | 159,3 | 523,6 | 10,0 | 17,0 | 1,85 |
| 50 | 3706 | 164,0 | 539,0 | 10,1 | 17,0 | 1,50 |

Relative change from reference to modified engine

| Load | Power | SFOC (MDO) | CO2 | SOx | NOx | PM |
|------|-------|------------|-----|-------|-------|-------|
| % | kW | % | % | % | % | % |
| 85 | - | 3,5 | 3,5 | -28,5 | -80,0 | -49,7 |
| 50 | - | 2,6 | 2,6 | -29,2 | -80,0 | -50,0 |

The ship

The ship's exhaust gas emissions, when operating at service speed, are shown in the tables below, for the modified as well as the reference ship. The 'at sea ballast exchanging' column has been omitted for the modified ship, because of its ballast water treatment plant.

GSF concept project (modified Seahorse 35)

| | | normal at sea | manoeuv. in port unloading (cranes) | in port loading | total | |
|--------------------------|--------|---------------|-------------------------------------|-----------------|--------|--------|
| operating days / year | | 230 | 10 | 60 | 360 | |
| main engine | | | | | | |
| power/SMCR | % | 85 | 50 | | | |
| power | kw | 6050 | 3559 | | | |
| FO consumption | t/year | 5504 | 144 | | 5.648 | |
| CO2 emission | t/year | 18089 | 472 | | 18.562 | |
| SOx emission | t/year | 4,7 | 0,1 | | 5 | |
| NOx emission | t/year | 113,6 | 2,9 | | 116 | |
| PM emission | t/year | 6,2 | 0,1 | | 6 | |
| diesel generators | | | | | | |
| electrical load | kw | 494 | 550 | 866 | 361 | |
| engine power | kw | | 579 | 912 | 380 | |
| FO consumption | t/year | | 28 | 263 | 109 | 400 |
| CO2 emission | t/year | | 89 | 843 | 351 | 1.283 |
| SOx emission | t/year | | 0,1 | 0,6 | 0,2 | 1 |
| NOx emission | t/year | | 1,4 | 13,0 | 5,4 | 20 |
| PM emission | t/year | | 0,3 | 2,6 | 1,1 | 4 |
| oilfired boiler | | | | | | |
| steam production | kg/h | | | 782 | 782 | |
| FO consumption | t/year | | | 84 | 84 | 169 |
| CO2 emission | t/year | | | 271 | 271 | 542 |
| SOx emission | t/year | | | 0,2 | 0,2 | 0 |
| NOx emission | t/year | | | 0,3 | 0,3 | 1 |
| total ship | | | | | | |
| FO consumption | t/year | 5.504 | 171 | 347 | 194 | 6.216 |
| CO2 emission | t/year | 18.089 | 561 | 1.114 | 622 | 20.387 |
| SOx emission | t/year | 5 | 0 | 1 | 0 | 6 |
| NOx emission | t/year | 114 | 4 | 13 | 6 | 137 |
| PM emission | t/year | 6 | 0 | 3 | 1 | 10 |

**reference ship
(Seahorse 35 "as is")**

| | | normal at sea | at sea ballast exchange | manoeuv. | unloading | loading | total |
|--------------------------|--------|---------------|-------------------------|----------|-----------|---------|---------------|
| operating days / year | | 225 | 5 | 10 | 60 | 60 | 360 |
| main engine | | | | | | | |
| power/SMCR | % | 85 | 85 | 50 | | | |
| power | kw | 6300 | 6300 | 3706 | | | |
| FO consumption | t/year | 5420 | 120 | 146 | | | 5.686 |
| CO2 emission | t/year | 17812 | 396 | 479 | | | 18.687 |
| SOx emission | t/year | 340,2 | 7,6 | 9,0 | | | 357 |
| NOx emission | t/year | 578,4 | 12,9 | 15,1 | | | 606 |
| PM emission | t/year | 62,9 | 1,4 | 1,3 | | | 66 |
| diesel generators | | | | | | | |
| electrical load | kw | 376 | 485 | 484 | 875 | 375 | |
| engine power | kw | 396 | 511 | 509 | 921 | 395 | |
| FO consumption | t/year | 427 | 12 | 24 | 265 | 114 | 843 |
| CO2 emission | t/year | 1405 | 40 | 80 | 872 | 374 | 2.771 |
| SOx emission | t/year | 26,8 | 0,8 | 1,5 | 16,6 | 7,1 | 53 |
| NOx emission | t/year | 24,6 | 0,7 | 1,4 | 15,3 | 6,5 | 48 |
| PM emission | t/year | 4,3 | 0,1 | 0,2 | 2,7 | 1,1 | 8 |
| oilfired boiler | | | | | | | |
| steam production | kg/h | | | | 782 | 782 | |
| FO consumption | t/year | | | | 89 | 89 | 179 |
| CO2 emission | t/year | | | | 278 | 278 | 555 |
| SOx emission | t/year | | | | 5,3 | 5,3 | 11 |
| NOx emission | t/year | | | | 0,7 | 0,7 | 1 |
| total ship | | | | | | | |
| FO consumption | t/year | 5.847 | 133 | 170 | 355 | 203 | 6.708 |
| CO2 emission | t/year | 19.217 | 436 | 560 | 1.150 | 651 | 22.014 |
| SOx emission | t/year | 367 | 8 | 11 | 22 | 12 | 420 |
| NOx emission | t/year | 603 | 14 | 17 | 16 | 7 | 656 |
| PM emission | t/year | 67 | 2 | 2 | 3 | 1 | 74 |

The ship emission calculations are based on the above mentioned figures for the main engine, as well as the following values concerning some of the other components.

| Calculation basis | | |
|--------------------------------|-----------|--------------|
| SMCR (GSF concept) | kw | 7.118 |
| SMCR (reference ship) | kw | 7.412 |
| scrubber efficiency SOx | - | 0,98 |
| scrubber efficiency PM | - | 0,80 |
| generator efficiency | - | 0,95 |

Relative emission reduction

Combining the two tables above, the relative emission reductions, have been calculated both when operating at service speed, and on an annual basis.

Emission reduction

| | normal at sea % | annual basis % | |
|--------------------------|--------------------|-------------------|---|
| main engine | | | |
| power | -4,0 | | prop./nozzle, twisted rudder & Costa bulb |
| FO consumption | -0,7 | -0,7 | increased SFOC |
| CO2 emission | -0,7 | -0,7 | increased SFOC |
| SOx emission | -98,6 | -98,6 | EGR scrubber og exh.scrubber |
| NOx emission | -80,8 | -80,8 | EGR og WIF |
| PM emission | -90,3 | -90,3 | EGR scrubber og exh.scrubber |
| diesel generators | | | |
| FO consumption | -100,0 | -51,9 | WHR |
| CO2 emission | -100,0 | -53,0 | slightly reduced due to MGO |
| SOx emission | -100,0 | -98,4 | MGO |
| NOx emission | -100,0 | -58,6 | reduced due to MGO |
| PM emission | -100,0 | -51,9 | |
| oilfired boiler | | | |
| FO consumption | | -5,4 | slightly reduced due to MGO |
| CO2 emission | | -2,4 | slightly reduced due to MGO |
| SOx emission | | -97,0 | MGO |
| NOx emission | | -53,2 | MGO |
| total ship | | | |
| FO consumption | -7,7 | -7,2 | SMCR (GSF concept) kw 7.118 |
| CO2 emission | -7,7 | -7,2 | SMCR (reference ship) kw 7.412 |
| SOx emission | -98,7 | -98,6 | scrubber efficiency SOx - 0,98 |
| NOx emission | -81,6 | -79,1 | scrubber efficiency PM - 0,80 |
| PM emission | -90,9 | -86,0 | generator efficiency - 0,95 |

Resulting exhaust gas emission reductions due to all the measures, mentioned above, are:

Emission reduction

| | normal at sea % | annual basis % |
|-------------------|-----------------------|----------------------|
| total ship | | |
| FO consumption | -7,7 | -7,2 |
| CO2 emission | -7,7 | -7,2 |
| SOx emission | -98,7 | -98,6 |
| NOx emission | -81,6 | -79,1 |
| PM emission | -90,9 | -86,0 |

29

© 2009, Grontmij | Carl Bro A/S



4.5 Deadweight loss

The total lightweight increase due to the modifications is estimated to app. 160 t, which must be deducted from the deadweight. The payload, at a given arrival draught, may be further reduced by the weight of the anolyte (generated onboard for ballast treatment), which will increase during the loaded voyage, from zero at the start to about 55 t at arrival. If the ship is loaded to scantling draught, however, the fuel consumption during the voyage will normally compensate this.

4.6 Economical consequences

Capital expenditure

The total investment necessary, in order to install all the measures listed in this study, amounts to about 5.2 mill USD, corresponding to app. 22 % on top of the current estimated newbuilding price at a Chinese shipyard. A rough price break-down, is seen in the table below. The prices include both equipment purchase and installation cost, at a far-eastern yard. It must be emphasized, that the prices are rough estimates, based on preliminary figures from the equipment vendors.

Additional weight (estimate)**160 t****Additional cost (estimate)**

| | USD |
|--|-----------|
| Speed nozzle/optimized propeller | 700.000 |
| Twisted spade rudder with Costa bulb | 160.000 |
| Water in fuel (WIF) | 200.000 |
| Exhaust gas recirculation (EGR) | 600.000 |
| Waste Heat Recovery system (WHR) | 1.250.000 |
| Exhaust Gas Scrubber | 1.200.000 |
| Ducted/direct air intake for main engine | 20.000 |
| Optimised coolers and cooling pumps | 150.000 |
| Auxiliary engine operation on marine gas oil (MGO) | - |
| High capacity fresh water generator | 50.000 |
| Installation of Ballast Water Treatment System (BWT) | 810.000 |
| | 5.140.000 |

**Estimated price for a Seahorse 35 is 22-25 mill. USD
(Chinese yard)**



32

© 2009, Grontmij | Carl Bro A/S

Operational expenditure

This figure includes changes in the cost of fuel and other consumables, spares, maintenance time and crew training. Only two major costs will be mentioned here, the change in fuel cost and the cost of sodium hydroxide for neutralization of scrubber water.

Change in annual cost (fuel and sodium hydroxide)

| | concept | basis | Difference | | |
|--------------------------|---------|-------|------------|-------|-----------------|
| | | | consump. | price | cost |
| main engine | | | | | |
| HFO consumption t/year | 5.648 | 5.686 | t/year | \$/t | \$/year |
| MGO consumption t/year | 0 | 0 | | | |
| diesel generators | | | | | |
| HFO consumption t/year | 0 | 843 | | | |
| MGO consumption t/year | 400 | | | | |
| oilfired boiler | | | | | |
| HFO consumption t/year | 0 | 179 | | | |
| MGO consumption t/year | 169 | 0 | | | |
| total ship | | | | | |
| HFO consumption t/year | 5.648 | 6.708 | -1.060 | 470 | -498.182 |
| MGO consumption t/year | 569 | 0 | 569 | 650 | 369.640 |
| NaOH (1% of HFO cost) | x | 0 | | | 26.544 |
| cost change | | | | | -101.998 |

The cost of sodium hydroxide has been calculated to about 1 % of the cost of heavy fuel oil (see calculation in the appendices). Based on the annual consumption figure and the price from the table above, this amounts to about 26.500 USD/year.

The sum of these two figures may be rounded to an annual saving of about 100.000 USD/year.

5 EMERGING TECHNOLOGIES

5.1 Air Lubrication and/or micro bubbles

Several different air lubrication systems have been proposed and tested, but at present none of these are judged to give reliable advantages for this concept study, and this technology has consequently been left out.

5.2 Low friction bottom paint

Silicone based paint systems are in operation on large container vessels, and are reported to give reductions in propulsive power of around 4 – 8 %. High speed, without long periods in between are, however, crucial in order to avoid fouling. For a relative slow ship, like a handy size bulker, which furthermore may spend relatively long periods without sailing, this technology is not at present judged to be relevant.

6 OPERATIONS

6.1 Effect of speed reduction

Speed reduction is the most efficient way of reducing both fuel consumption and emissions, and as it is the 'active component' of many operational measures, it will be considered in this case study.

In the spreadsheet below the effect of speed reduction on CO₂ emissions is illustrated for the concept ship. In the 10 columns, the consequences of 10 different speeds are calculated. The set of speeds considered is the present service speed of the basis ship multiplied by a speed ratio varying from 1 to 0.1. The propulsive power is assumed to vary with the third power of the speed (often it is more). The fuel consumption, electrical power requirement, WHR power, DG power and emissions during 'normal at sea' operations vary with the main engine power. The number of days spent in 'normal at sea' mode is increased corresponding to the lower speed.

The emissions and number of days spent in all other conditions are kept unchanged. This gives an equivalent annual operation period, in which the amount of transport work done is unchanged. The CO₂ emissions are calculated as the ratio between the emissions for the equivalent annual voyage period, and the annual emissions when operating at basis speed, i.e. a speed ratio of 1.

The total duration of the voyage is expressed as a total time duration factor. This factor also expresses the number of equivalent ships needed to do the same transport work per year. The number of ships employed does not, however, influence the CO₂ emissions for a given amount of transport work.

| speed ratio | | 1,0 | 0,9 | 0,8 | 0,7 | 0,6 | 0,5 | 0,4 | 0,3 | 0,2 |
|--|----|-------------|-------------|-------------|-------------|-------------|-------------|-------------|-------------|-------------|
| service speed (average between full load and ballast) | kn | 14,6 | 13,1 | 11,7 | 10,2 | 8,8 | 7,3 | 5,8 | 4,4 | 2,9 |
| days | | 230 | 256 | 288 | 329 | 383 | 460 | 575 | 767 | 1150 |
| main engine during cruising (normal at sea) | | | | | | | | | | |
| ME power ratio (rel. to 85 % SMCR) | | 1,000 | 0,729 | 0,512 | 0,343 | 0,216 | 0,125 | 0,064 | 0,027 | 0,008 |
| CO ₂ emission | t | 18.089 | 14.652 | 11.577 | 8.864 | 6.512 | 4.522 | 2.894 | 1.628 | 724 |
| diesel generators during cruising (normal at sea) | | | | | | | | | | |
| ME related electrical load | kw | 222 | 162 | 114 | 76 | 48 | 28 | 14 | 6 | 2 |
| total electrical load | kw | 494 | 434 | 386 | 348 | 320 | 299 | 286 | 278 | 273 |
| available power from steamturbine (WHR) | kw | 500 | 450 | 400 | 350 | 300 | 250 | 200 | 150 | 100 |
| diesel generator power (remaining) | kw | 0 | 0 | 0 | 0 | 20 | 49 | 86 | 128 | 173 |
| CO ₂ emission | t | 0 | 0 | 0 | 0 | 123 | 369 | 801 | 1588 | 3236 |
| emission in port and during manouvring (constant) | | | | | | | | | | |
| days | | 130 | 130 | 130 | 130 | 130 | 130 | 130 | 130 | 130 |
| CO ₂ emission | t | 2.298 | 2.298 | 2.298 | 2.298 | 2.298 | 2.298 | 2.298 | 2.298 | 2.298 |
| total for ship | | | | | | | | | | |
| days pr. ref. transport | | 360 | 386 | 418 | 459 | 513 | 590 | 705 | 897 | 1280 |
| total duration ratio | | 1,000 | 1,071 | 1,160 | 1,274 | 1,426 | 1,639 | 1,958 | 2,491 | 3,556 |
| CO ₂ emission | t | 20.387 | 16.950 | 13.875 | 11.162 | 8.933 | 7.189 | 5.994 | 5.514 | 6.257 |
| total duration ratio | | 1,00 | 1,07 | 1,16 | 1,27 | 1,43 | 1,64 | 1,96 | 2,49 | 3,56 |
| CO₂ emission ratio | | 0,93 | 0,77 | 0,63 | 0,51 | 0,41 | 0,33 | 0,27 | 0,25 | 0,28 |

The graphs below illustrate the variation with speed of the 'CO₂ emission ratio' and the 'total time duration ratio'. The latter has been multiplied by 0.1. The speeds below 8 - 10 knots are hardly relevant, and have been included as a consistency check only. It appears, that a speed reduction from the 14.6 knots service speed of the basis ship (average between ballast and full load) to about 10.3 knots is going to half the fuel consumption and emissions.

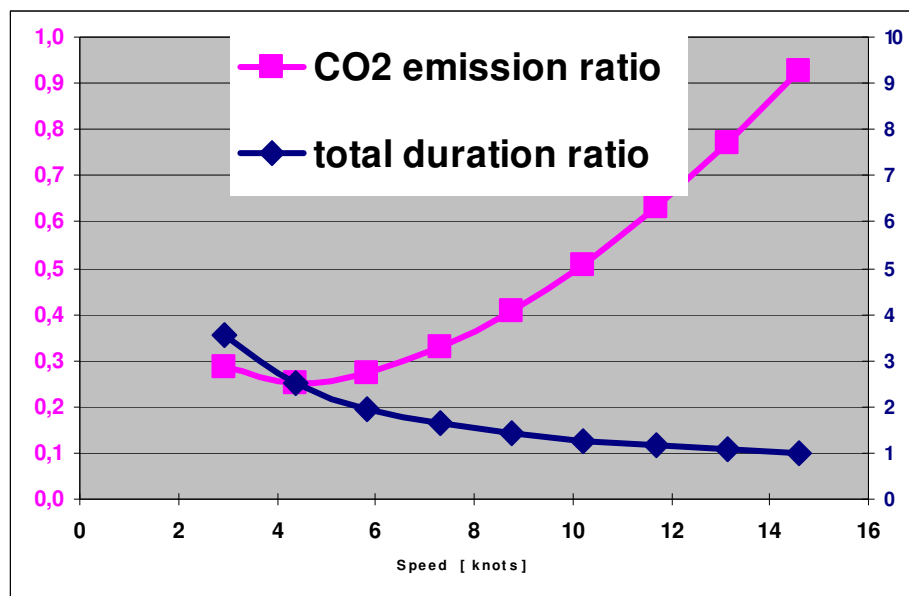

7 CONCLUSIONS AND FINAL REMARKS

The goal for Green Ship of the Future was to get 90% NO_x, 90% SO_x and 30% CO₂ reduction. The first two goals were achieved by adding emission technologies as described in this report, but only 7.2 % CO₂ reduction was obtained with unchanged ship speed.

As it has been shown, the large emission reductions particularly concerning NO_x and SO_x are possible using technologies like, WIF, EGR and scrubber, but for CO₂ substantial reductions with emission reducing technologies known today will only be possible by lowering the ship speed.

The NO_x and SO_x reductions are obtained at a higher cost, both in terms of investment and operating costs. Also higher electrical power is required to run the exhaust gas reducing systems, and finally an increased specific fuel oil consumption of the main engine is a consequence of the NO_x reducing technologies. This power can, scarcely, be supplied by the WHR system, but in principle it could have been used for propulsion, which would have further reduced fuel consumption and emissions.

If the goal of 30% CO₂ reduction must be achieved, a speed reduction of about 2 knots is needed.